

# UK KOSMIC KOLOR URETHANE ENAMEL KANDYS

## GENERAL INFORMATION

Kosmic Kolor® urethane enamel Kandys may be applied over any of our SHIMRIN® Universal Base Coats. Use only Kosmic Reducers. Do not mix other companies products with House of Kolor's products, as many have proven to be incompatible. *This includes other companies' primers, sealers, base coats, reducers and clears.*

## IMPORTANT NOTE

Use only our Kosmic Reducers. Carefully choose the correct reducer based on your spray booth temperature with fan running. If no spray booth is available, use a faster dry reducer. Kosmic Reducers have very noticeable differences in dry times. For additional flow, add more reducer of the same speed or mix with a slower reducer. ***See tech sheet for more information on Kosmic Reducers.***

## IMPORTANT INFORMATION ABOUT UK'S

The following UK's have a tendency to bleed through when artwork applied directly over them. Always use our Bleed Check Sealer SBS10 before any artwork is applied. ***See tech sheet for more information on Bleed Check Sealer.*** A catalyzed clear coat will NOT stop their tendency to bleed. However, if multiple applications of clear (2 or more) and proper flash time between coats is observed the leaching of color into the clear is reduced.

The UK products that have a tendency to bleed are: UK03, UK05, UK06, UK10, and UK13.

## IMPORTANT INFORMATION ABOUT UK18 KANDY PINK

UK18 Kandy Pink has limited light fastness and should only be used on products that have limited exposure to sunlight. Use with discretion. UK18 is recommended for show vehicles.

## 1. PREPARATION

Read "TECH REP" thoroughly before you begin painting. To prevent filler bleed through, apply 3 coats of our KP2CF Chromate Free Kwikure Epoxy Primer, KD2000 Direct To Metal Epoxy Primer or our KP21 Kwikure Epoxy Primer. ***See tech sheets for more information on KP & KD Primers.***

## 2. GROUND COAT

- Primer (KP2CF, KD2000, KP21)
- Sealer (KO-SEAL® II)
- SHIMRIN® Bases

***VEHICLE MUST BE ONE EVEN COLOR BEFORE APPLICATION OF BASE COAT.*** Primers and sealers may be used as a ground coat. Use HOUSE OF KOLOR KO-SEAL® II (available in three colors). Use a sealer closest to the base color for faster coverage of base coats. Follow label instructions. Allow flash time on sealer. ***See tech sheets for more information on KO-SEAL® II, and KP Primers.***

**NOTE:** Sealer is not a cure all for poor preparation and does not prevent discoloration or bleeding. You may also use any of our Kosmic Kolor® SHIMRIN® Bases: Designer Pearls, Graphic Colors, Neons, Metallics, etc., for the ground coat. The color of the ground coat will vary the final color. This is an excellent place for creativity. Follow labels instructions. Allow flash time on each coat of ground color. ***See appropriate tech sheets for application instructions.***

## 3. BASE COAT

You may use any of our SHIMRIN® Bases under the Kosmic Kolor® urethane enamels. Follow label instructions. Allow flash time on each coat of base color. ***See individual tech sheets for specific instructions.***

# UK KOSMIC KOLOR URETHANE ENAMEL KANDYS (continued)

## 4. KOSMIC KOLOR KANDY COAT (UK)

Kosmic Kandys may be applied over any of our SHIMRIN® bases or Kosmic Solid Colors. Always spray a test panel. Mix by volume, 2 parts Kandy to 1 part KU100 Catalyst to 1 part Kosmic Reducer. REDUCE ONLY WITH OUR KOSMIC REDUCERS. Use a reducer best suited to your shop conditions. **See tech sheet for more information on reducers.**

**NOTE:** 2-4 ounces of reducer (per mixed quart) may be added for better control and flow out.

**NOTE:** KU100 Catalyst is moisture sensitive and will not keep for long periods once opened. When doing small jobs, buy smaller containers to prevent spoilage. Keep container tightly sealed.

Strain the paint into the paint gun. Air pressures vary, use Gun Mfgs. recommendations for fluid tip & air pressure. General recommendation would be a 1.2 to a 1.5 needle nozzle set, but this will vary from gun to gun. Apply 5 to 6 coats to achieve proper color. Start with 3 medium wet coats first, with 75% spray overlap. Finish with 2 to 3 full wet coats with 50% spray pattern overlap. Gun distance while spraying should be approximately 6 inches. Walk long objects. Allow flash time between coats.

**URETHANE FLASH TEST -PAINT SHOULD BE STICKY AND NOT STRING WHEN TOUCHED AT THE WETTEST POINT BEFORE NEXT COAT IS APPLIED.**

**NOTE:** Too long a dry time between coats may cause lifting. If finish feels dry, allow 12 hours at 70 degrees before re-coating. Scuff with maroon scuff pad to remove gloss or lightly wet sand with 500 or 600 wet. Use caution as too aggressive sanding can cause light and dark spots in the Kandy.

**NOTE:** Color strength will vary based on base color, number of Kandy coats, type and number of clear coats, and spray technique. LIGHTER BASE COLORS REQUIRE MAXIMUM NUMBER OF KANDY COATS FOR LONGEVITY. A base color tinted near the Kandy color eases application and improves longevity.

## 5. KANDY APPLICATION TECHNIQUES

The application of "Kandy Type" finishes are among the most demanding of all finishes applied. Great attention must be paid in spray gun settings, number of coats and basic spray gun techniques. The following steps, when observed, provide consistent results.

### Setting up the Spray gun

- Know the equipment
- Check spray gun pattern, it must be consistent. (See Diagram One)
- Turn fluid knob in, to restrict trigger pull and reducer amount of Kandy delivered. This must be done for the first two to three coats to avoid streaking. A 75% pattern overlap is mandatory.

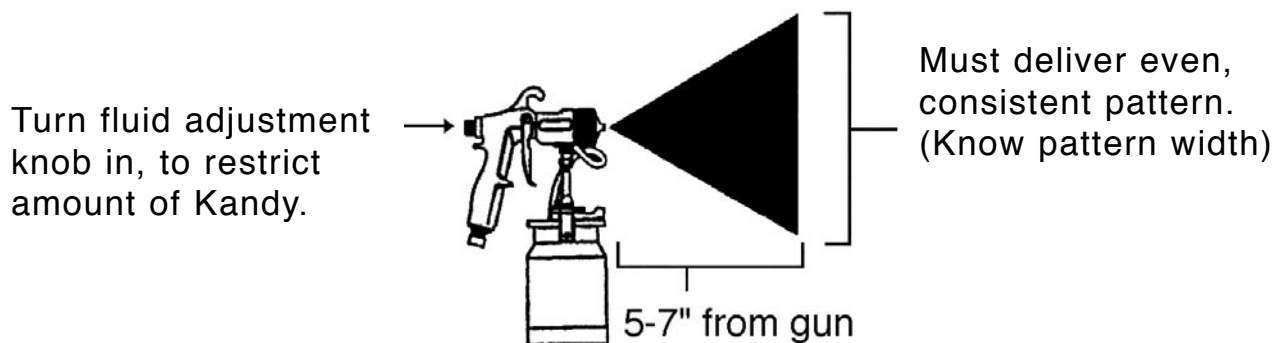

Diagram One

# UK KOSMIC KOLOR URETHANE ENAMEL KANDYS (continued)

## Application- The First 2 to 3 Coats

- Apply Kandy with recommended pattern overlap. (See Diagram Two)
- Spray gun should be 4 to 6 inches from surface.
- Do not apply Kandy panel to panel, spray entire length of object.
- Spray in straight lines, do not follow body lines. (See Diagram Three)

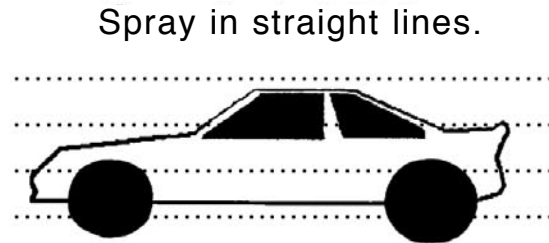
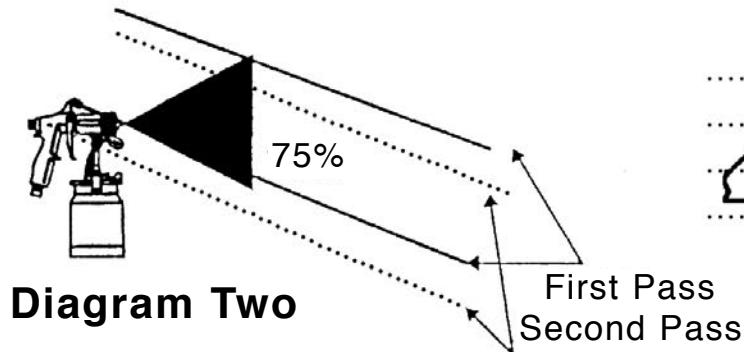

Diagram Three

## Application- Final Coats

- Adjust fluid knob for a larger pattern 5-7 " apply additional 2 to 3 coats with 50% overlap.
- Allow each coat to stop "stringing" before applying next coat. Do not allow coats to completely dry to touch between coats.
- Apply 2 to 3 coats of House of Kolor UC or UFC urethane clear, allowing Kandy only enough time to stop "stringing". Do not allow Kandy to completely dry before clearing or wrinkling and lifting is likely to occur.

**NOTE:** Do not use SG100 Intercoat Clear directly over the UK Kandy. This is a base coat material. Use our Catalyzed UC or UFC Clear only.

## 6. POLISHING

A: Cutting and buffing Top Coat Clears. If UC35 or UC01 is used, allow 12-14 hour dry times at a consistent 70-degree. UFC35, UFC01 or UFC19 allow 24 to 48 hours. Color sand with 1200P grit, finish with 2000P-3000P grit and polish with a 1500 to 1750 rpm polisher. Use the compounds and pads of your choice. For longer times, use finer cutting sand papers, such as 2000P, 3000P or 4000P grit.

After 60 days, the vehicle may be waxed. We recommend using a quality non-abrasive Carnauba wax. **See tech sheet for more information on Polishing & Finishing.**